

PROWADZENIE PŁYT WYPYCHACZY TULEJA Z ROTACYNYM SYSTEMEM KULKOWYM

DKA

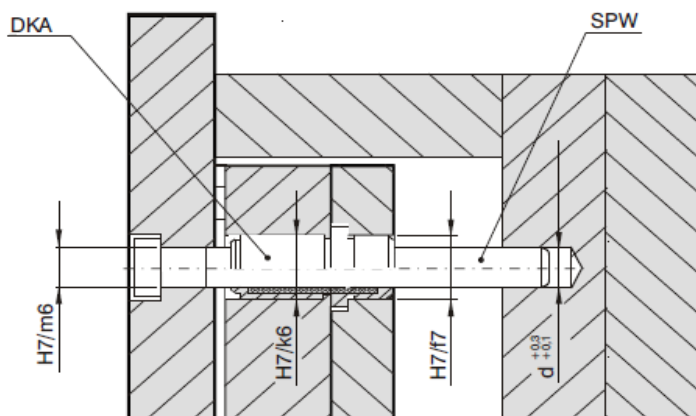
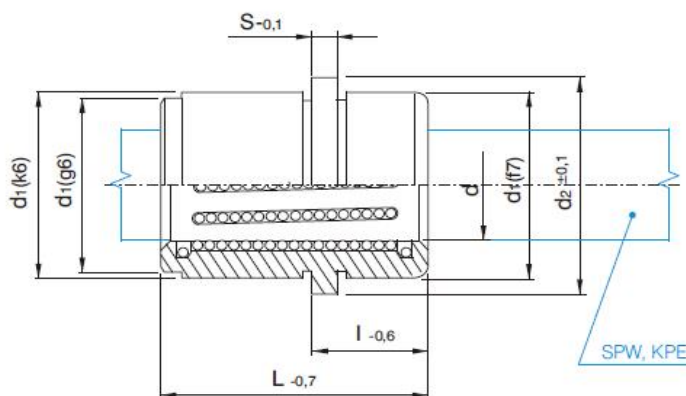

d	d1	d2	s	l	L	NR KAT.
12	22	26	6	12	26	DKA-1226
18	30	35		17	35	DKA-1835
24	38	43		22	45	DKA-2445
30	46	52		27	55	DKA-3055